

A row of stainless steel kegs in a brewery setting. The kegs are arranged in a line, with the foreground ones being more prominent. They have black handles and caps. In the background, there are larger stainless steel tanks and pipes, suggesting a professional brewing environment. The lighting is warm and focused on the kegs.

ZEGKEG

LOGISTIKA

ZEG TECHNICKÉ SPECIFIKACE

Název	ZEG KEG 30L	ZEG KEG 20L	ZEG KEG 10L
Trvanlivost	Až 18 měsíců od data výroby, dle typu nápoje a skladování		
Tlak v balení	+0,85 / -0,15 bar		
Metoda plnění	Protitlak – vrchem/spodem		
Plyn v sudu	Dusík		
Adaptér	S/A		
Objem	30 litrů	20 litrů	10 litrů
Průměr/výška	296 mm / 580 mm	237 mm / 575 mm	237 mm / 362 mm
Hmotnost KEGU	1,25 kg	0,94 kg	0,94 kg
Teplotní rozpětí	od -20 °C do 40 °C		
Tlak dusíku – prázdný keg	1,5–2 bar		
Destruktivní tlak	> 8 bar		
Max. pracovní tlak	4 bar		
Materiály			
Obal	PET		
Podstavec	PP		
Ponorná trubice	HDPE		
Adaptér	PA/PP/TPE		
Balení – Export paleta (1200 mm × 1000 mm)			
1 vrstva ZEG KEGů	12 ks	20 ks	20 ks
1 paleta ZEG KEGů	4 vrstvy – 48 ks	4 vrstvy – 80 ks	6 vrstev – 120 ks
Balení – Euro paleta (1200 mm × 800 mm)			
1 vrstva ZEG KEGů	11 ks	15 ks	15 ks
1 paleta ZEG KEGů	4 vrstvy – 44 ks	4 vrstvy – 60 ks	6 vrstev – 90 ks



Stohování

ZEG KEG 10L

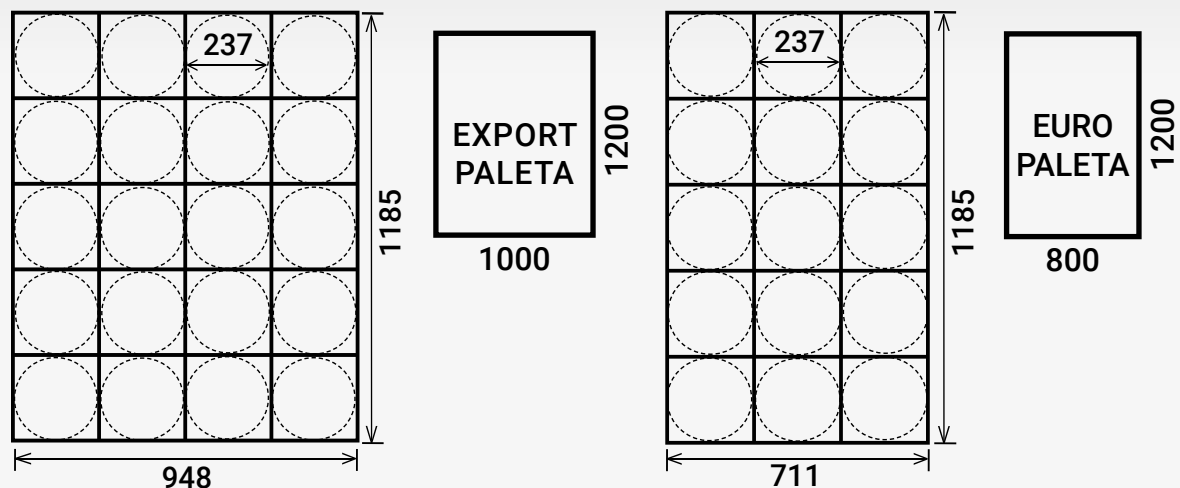

Příklady vrstvení – naplněné KEGy

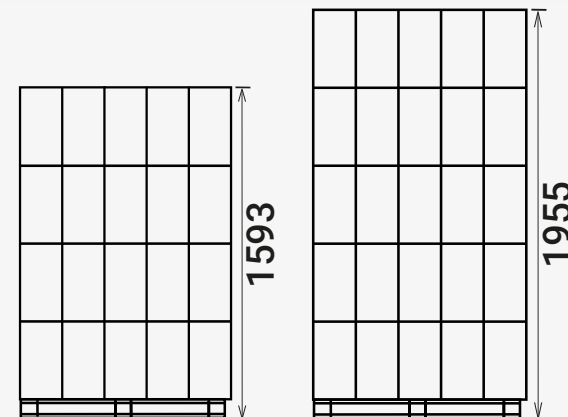

ZEG KEG 20L

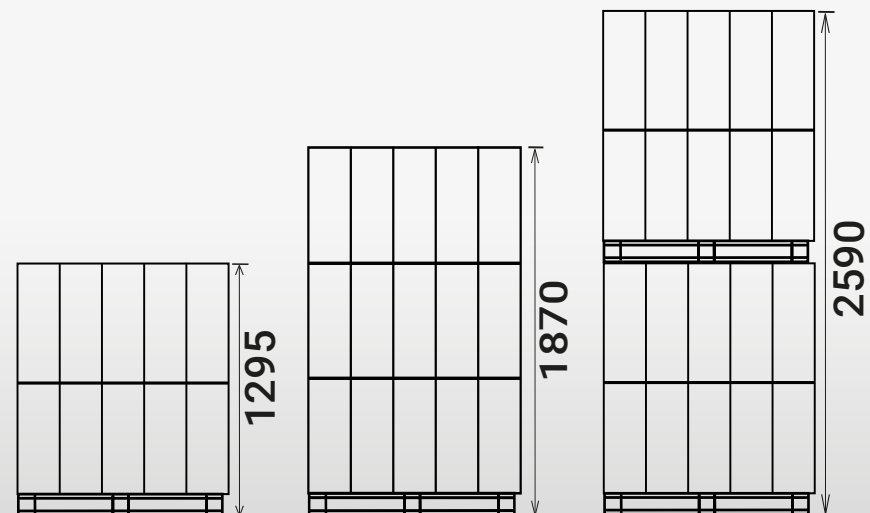
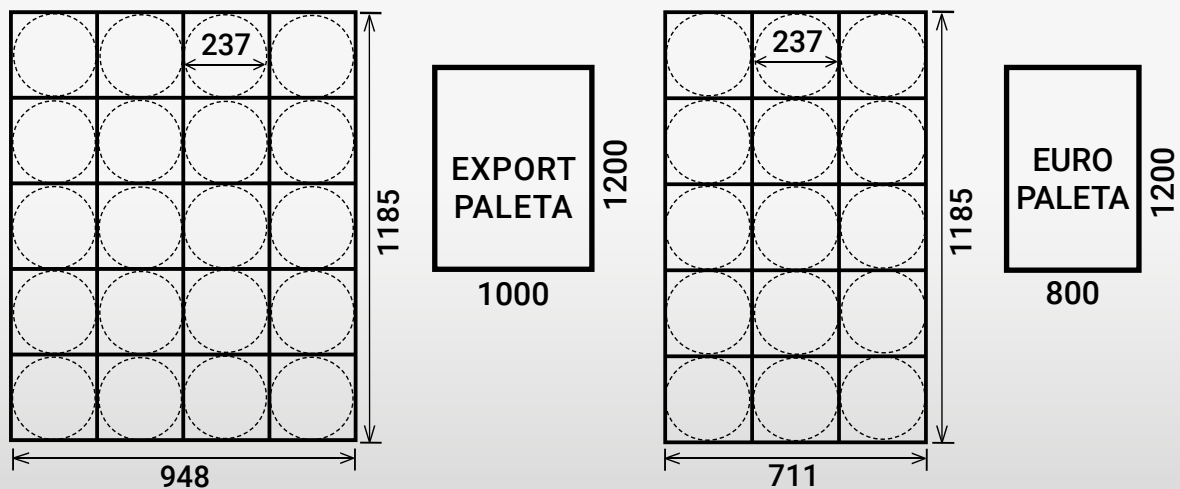

ZEG KEG 30L

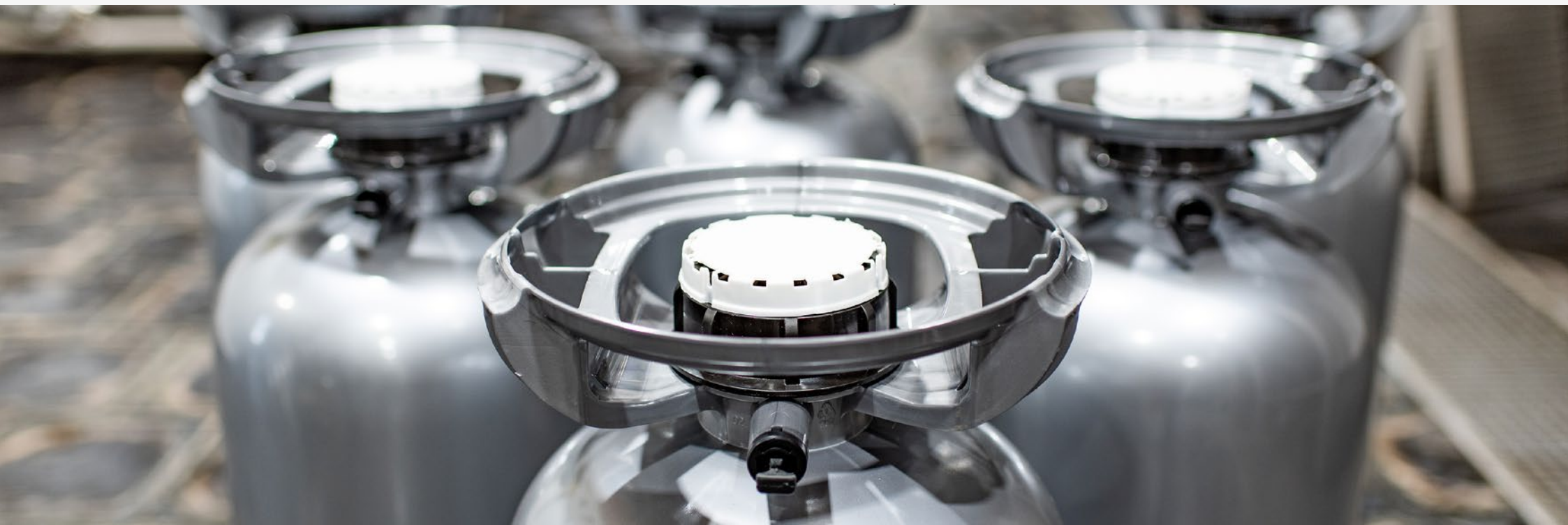
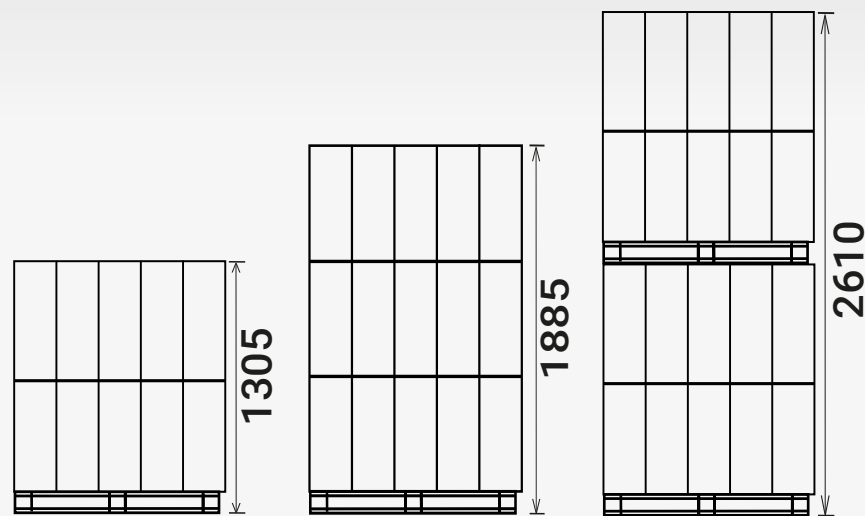
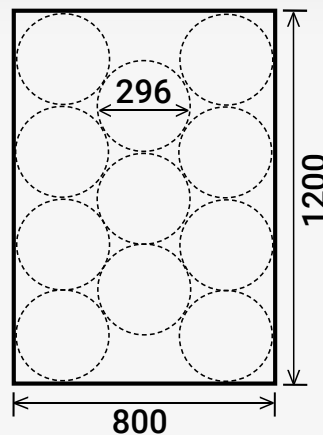
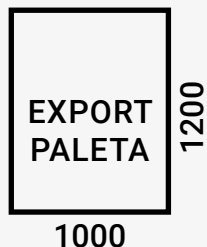
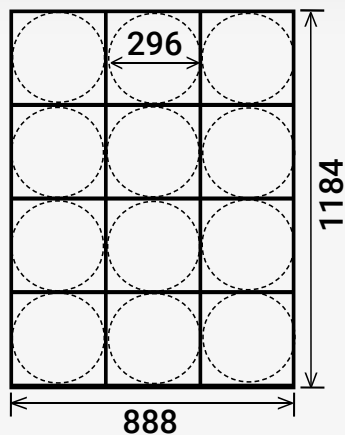

KONTAKT

Fakturační údaje

ADAM & PARTNER, s.r.o.

IČ: 26162351

DIČ: CZ26162351

Hradešínská 1102/4

101 00 Praha 10

Kancelář

Radlická office

Radlická 348/142

150 00 Praha 5

Obchodní kontakty

Pavel Štupák

Regional Sales Manager – Čechy

pavel.stupak@adam-partner.cz

tel.: +420 732 682 782

Markéta Hoffmannová

Regional Sales Manager – Morava, Vysočina

marketa.hoffmannova@adam-partner.cz

tel.: +420 732 682 692

www.smartpetobaly.cz

smartpet@adam-partner.cz



adam&partner

